

REFRIGERATION - CONTROLLING DIGITAL SCROLL

1 Introduction

Refrigeration applications such as retail and convenience stores are requesting more and more a system able to cope with varying load fluctuations especially with regard to efficiency, as energy costs continue to rise as a direct subsequence to environmental awareness.

Some means of capacity control is essential. Compressor capacity modulation can reduce energy consumption and compressor cycling. Emerson Climate Technologies has developed Digital Scroll™, a simple and unique method for modulating system capacity. Digital Scroll technology permits a step less range 10 to 100% capacity modulation of Copeland Scroll™ compressors for high, medium, and low temperature applications providing smooth, vibration free operation by axially unloading the compliant scrolls.

2 How Digital works

2.1 Compliance

Digital Scroll modulation is based on axial compliance. Axial compliance allows the fixed scroll to move vertically, by a very small amount, to ensure that the scrolls are always radially loaded with optimal force. This holds the two scrolls together, at all operating conditions, ensuring high efficiency.

When the Copeland Digital Scroll is operating in normal “Loaded” mode the compressor behaves just like a standard scroll compressor providing 100% capacity. Controlling the mechanical axial load is achieved when the solenoid valve is energized. The movement of discharge flow to suction lifts the fixed scroll, separating from the orbiting scroll. The compressor motor continues to run at normal speed but with no compression taking place. Modulation is achieved by alternate lifting and engaging the fixed (upper) scroll, which occurs in response to a pulse signal activated by the solenoid valve. Full lubrication is maintained at all times as the motor still operates 100% rpm in the unloaded state.

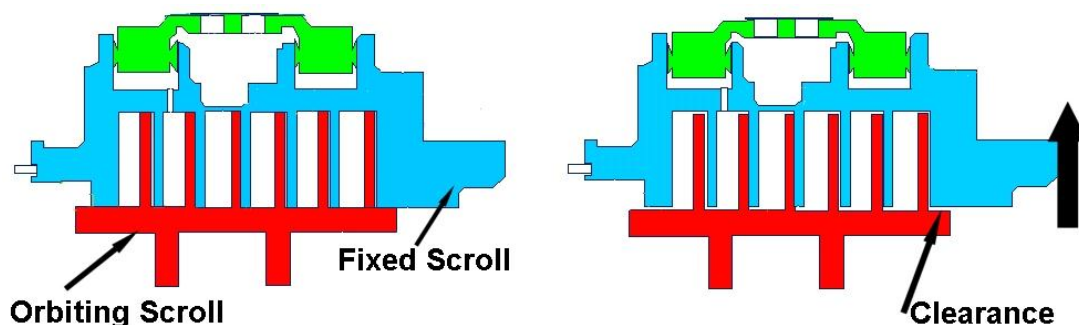

Figure 1: Axial compliance mechanism

The time period for a complete On/Off sequence is called the cycle time, and this can be between 10 and 30 seconds. The minimum loaded time is 2 seconds, to ensure that the scroll loading transition time is a small fraction of the total loaded time.

2.2 Piston, modulation chamber

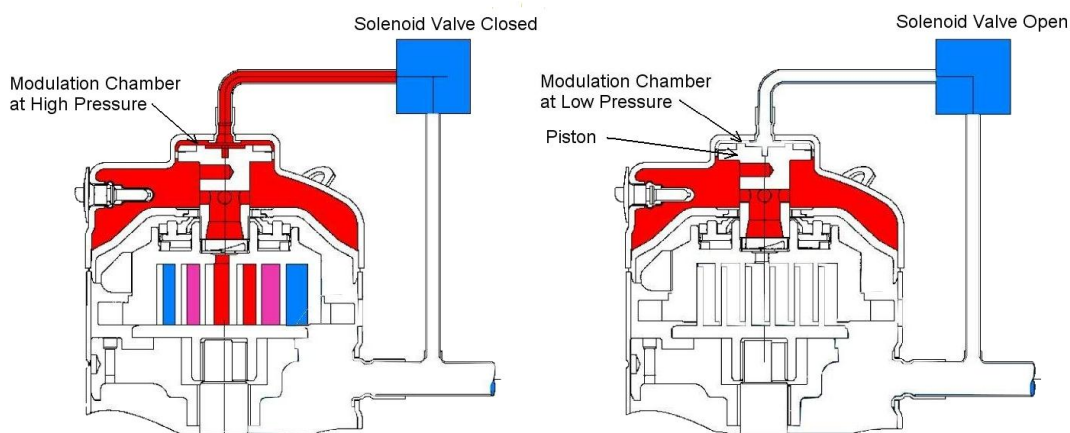

Figure 2: Section showing piston used to lift the fixed scroll

The Digital Scroll modulating mechanism is illustrated in **Figure 2**. In the top cap there is a piston which is connected to the fixed scroll. The diagram on the left shows the loaded state corresponding to normal scroll operation, ie, 100% compression. There is no pressure difference across the piston. This piston is actuated by gas pressure. The picture on the right shows the unloaded state.

As previously explained when the solenoid valve is energized (open) it allows the small volume of discharge pressure in the modulation chamber above the piston to communicate with suction pressure via the external tube. Discharge pressure on the lower side of the piston forces it upwards, bringing with it the upper scroll. A dynamic discharge valve is located at the scroll discharge port to prevent entry of high pressure gas into the scroll set during the unloaded state. When the solenoid is de-energized (closed), as shown on the left, pressure slowly increases within the modulation chamber via a small bleed hole until discharge pressure is reached and once more there is no force acting upon the piston. The upper scroll moves down to its normal contact position with the orbiting scroll, and the compliance mechanism is resumed.

2.3 Pulse width modulation

Digital Scroll requires a signal to open and close the solenoid valve. This is a pulse width modulated (PWM) signal. The compressor is switched between the loaded and unloaded states with a cycle time of typically 20 seconds. Duration of the scroll loaded state within this cycle time determines the capacity. This function of modulation frequency ensures that systems experience continuous capacity output from the compressor because of the thermal inertia damping effect. Motor power input drops to approximately 10% during the unloaded period.

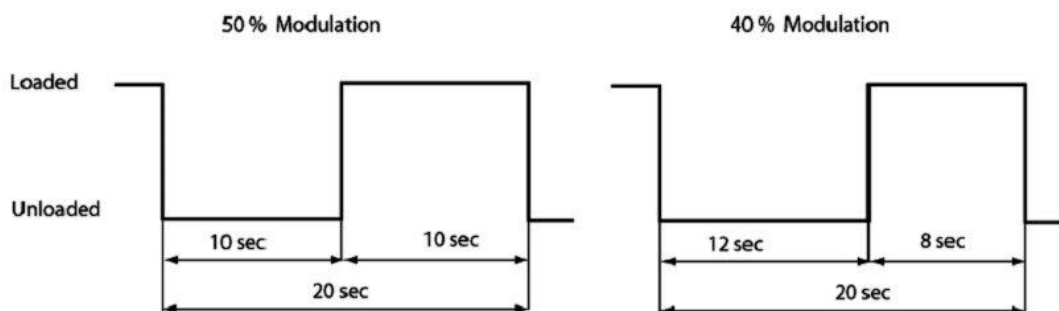

Figure 3: Digital PWM signal from the controller activates the unloading

3 Components for Digital control

3.1 Compressor

Digital Scroll models are designated by a letter “D” in the third character of the nomenclature. Low temperature Digital models ZFD also combine economizer operation. This is designated by the seventh character as letter “V” in the model description. Please refer to Copeland™ brand products Selection Software for available models.

Operating envelopes for Digital compressors are very similar to that of the equivalent standard scroll compressor. However, a 5.2 bar differential between discharge and suction must be maintained. Therefore, there is a small additional restriction to the lower right hand corner of the Digital envelopes as shown in **Figure 4**.

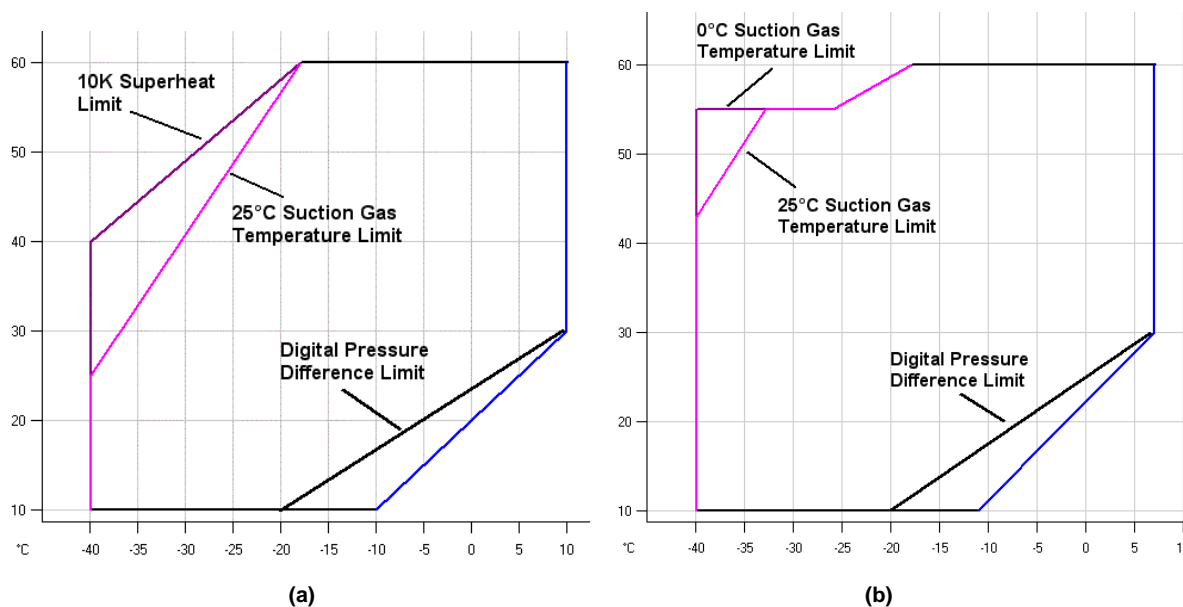

Figure 4: Operating envelopes for Digital Scroll compressors, (a) high, medium temperature ZBD models, (b) low temperature ZFD models

3.2 Solenoid and tubing

A special solenoid valve has been developed to meet the reliability requirements in the hot gas environment and hence only valves from Emerson Climate Technologies may be used. For correct operation, the mounting of the solenoid valve must be vertical, as shown in **Figure 5**.

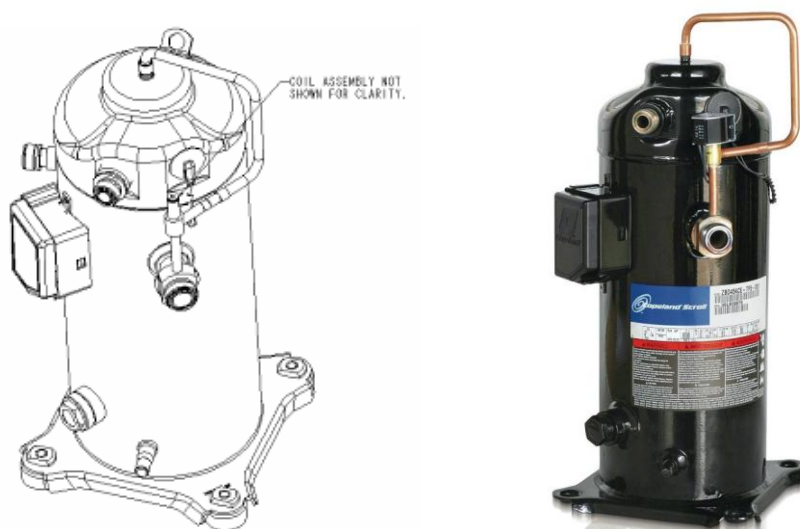

Figure 5: Configuration for solenoid valve and tubing

3.3 Control components

Components required for control are an electronic controller and suction pressure transmitter. The electronic controller sends the PWM signal modified in accordance with the pressure deviation from the set point using a built in algorithm.

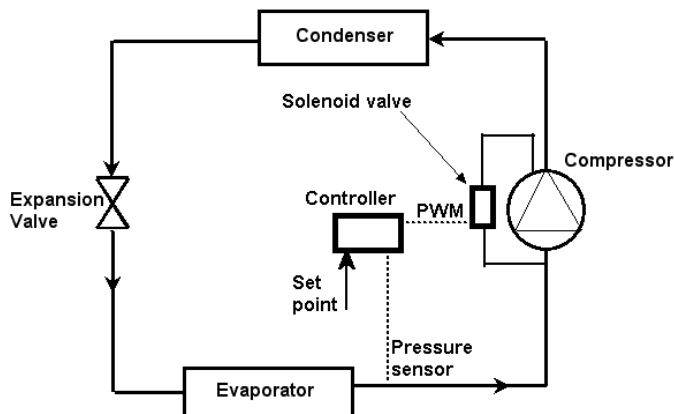

Figure 6: Control principle

4 Controlling Digital Scroll

The Emerson controllers EC2 and EC3 are specifically designed for Copeland Digital Scroll. Kits containing all the necessary components can be supplied by Emerson Climate Technologies and shipped with the ZBD and ZFD compressors. Other controllers can be used but require confirmation by Emerson Climate Technologies of their compatibility.

4.1 Controllers

4.1.1 EC2-552 Controller – Up to 2 compressors

Emerson controller EC2-552 is designed for a single Digital or two scroll compressor operation where one would be Digital scroll and the other a standard scroll compressor. A typical twin compressor application would be a condensing unit.

Based on the suction pressure, the EC2-552 will control the running operation of the compressors. The Digital compressor is programmed to be first in and last out (FILO), operation via a PWM output. The modulation cycle time can be set between 10 and 20 seconds and the capacity time can be adjusted down to 2 seconds (10% minimum) through the parameters of the controller. With two identical capacity compressors this will allow modulation down to 5% capacity. As illustrated in **Figure 8**, the logic is for the Digital to “fine tune” the system capacity between 5% - 100% as required. The fixed capacity scroll compressor is switched on when the Digital exceeds its maximum and off with its minimum modulation depending on the system capacity requirements.

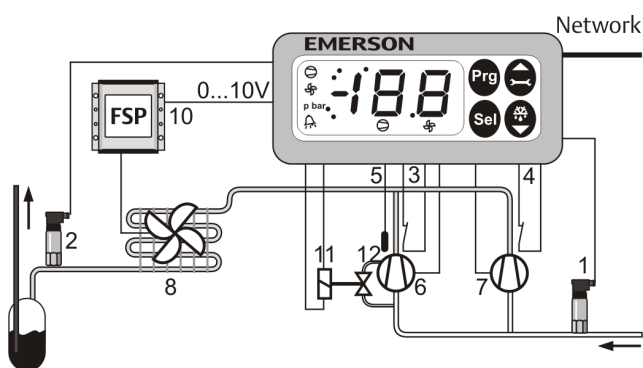

Figure 7: EC2-552 controls two compressors on one system



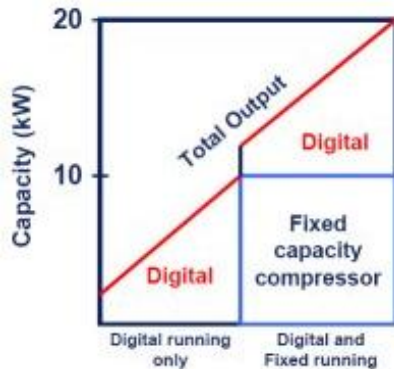

Figure 8: Total output 5 – 100% with two compressors

The input from the LP pressure transmitter is the reference parameter for the output signal to the compressors, and HP transmitter input is used to control fan speed via a 0 -10V output. An option of controlling 2 fans is available. The Emerson EC2-552 controller also has TCP/IP Ethernet communication capability.

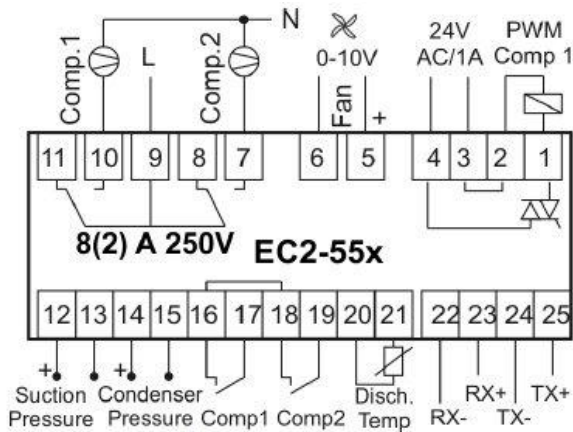

Figure 9: Wiring diagram for the EC2-55X controller

The PWM output needs to be configured to match the selected Digital solenoid coil rating (24V). The compressor contacts should be controlled with relays having gold plated contacts to ensure longevity.

To aid selection and provide application support to manufacturers and users, an EC2 kit is available containing the controller and its accessories. For full details see Quick Ordering Guide below.

4.1.2 Compressor rack controllers for Digital Scroll

Emerson Climate Technologies provides compressor rack controllers where a larger number of fixed standard capacity Scroll plus one Digital Scroll can be applied to provide complete modulated control for the larger system. As with the EC2 controller, control is based on suction pressure. The pack controller models are:

EC3-65X Controller – 1 Digital plus a maximum of 7 standard scroll compressors

Networking capability:

EC3-651 LON (open communication standard)

EC3-652 TCP/IP Ethernet

Figure 10: EC3-6XX Controller

ECD-000 Display Module

Available as an option; it displays the system temperatures, indicates system status and enables parameters to be modified.

Figure 11: ECD-000 Display



The EC3-65X series component schematic, wiring inputs/outputs are shown below:

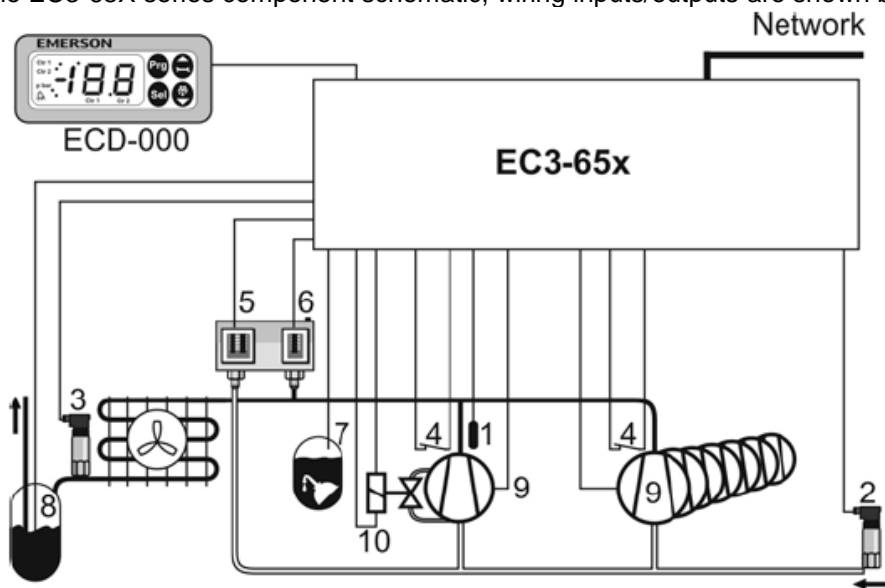

Figure 12: Schematic for the controller

KEY	
Inputs:	Outputs:
1. Compressors discharge temperatures	9. Up to 8 compressors EC3-65X
2. Suction pressure	10. Capacity control for Digital Scroll
3. Discharge pressure	
4. Serial alarm inputs for compressors	
5. Low pressure alarm	
6. High pressure alarm	
7. Oil level alarm	
8. Refrigerant level alarm	

Input/Output configuration for the EC3 Controller		
Description	I/O Specification	EC3-65X
Pressure sensor inputs	24V DC, 4...20 mA	2
Compressor output relays	SPDT contacts, AgCdO Inductive (AC 15) 250 V / 2A Heating (AC 1) 250 V / 8A	8
Digital Scroll control (Triac output)	Digital semi-conductor switch, 24 VAC/230 VAC	1
Alarm output (Triac)	Digital semi-conductor switch, 24 VAC/230 VAC	1
Serial alarm inputs for compressors	Digital input contacts, 24 VAC/DC or 230 VAC, two input voltage ratings provided	4
	Digital input contacts 24 VAC/DC or 230 VAC	
Dedicated alarm inputs for LP / HP, oil level and refrigerant level switches	Digital input contacts, 24 VAC/DC or 230 VAC, two input voltage ratings provided	4
Temperature 1 ambient	NTC 10 kΩ @ 25°C, -50°C...+50°C	1
Temperature input discharge (1)	NTC 86 Ω @ 25°C, -40°C...+180°C	1
Temperature input discharge (2, 3, 4)	1 MΩ @ 25°C, +50°C...+150°C	3

Table 1

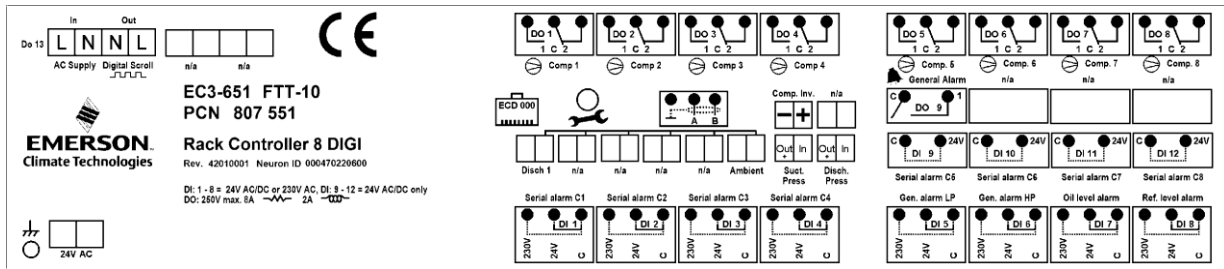

Figure 13: Wiring diagram for the EC3-651 Controller

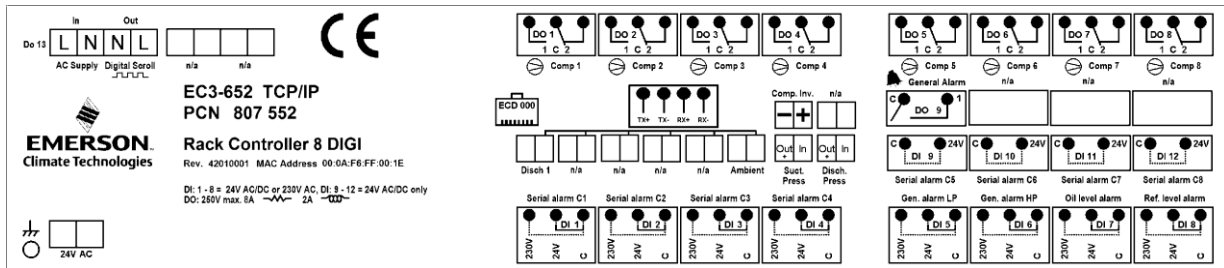

Figure 14: Wiring diagram for the EC3-652 Controller

EC3-DXX

The EC3-DXX series controller is a stand-alone universal superheat controller with built-in synchronization control for Digital Scroll and expansion valve elements of the refrigeration circuit. This is necessary in situations where evaporating and condensing pressures change rapidly when Digital Scroll modulates. This can be particularly true when using close coupled systems without large suction accumulators. In this situation the superheat control can react to the transitory pressure change when the scroll is not pumping. This can result in the control loop becoming unstable giving rise to further pressure fluctuations and liquid slugging.

The solution is to synchronize the superheat control with the cycling operation of the Digital Scroll solenoid valve so that the superheat control is only active when the compressor is “pumping”. During the unloaded part of the compressor cycle the superheat control is idle also. This is called Gated Superheat Logic.

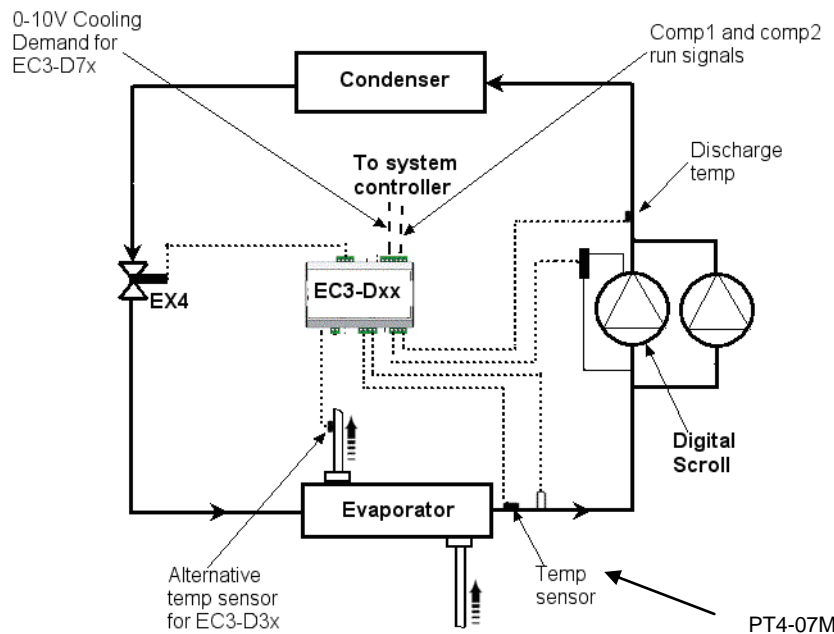

Figure 15: System diagram

For a single Digital Scroll compressor application, the superheat control is suspended when the compressor is not pumping.

If the Digital capacity requirement is <70% then the expansion valve will close in conjunction with the Digital modulation when the scroll sets are in the unloaded state.

If Digital capacity is >70%, then the valve will stay in its last position. For a dual compressor system the same applies when Digital Scroll is the only one operational.

On a dual compressor system the fixed capacity scroll compressor operates when a run signal is received. This is when a minimum of 50% system capacity is required. At this condition the expansion valve will be in continuous control mode even if the digital compressor runs at 10% duty cycle.

The expansion valve must react fast enough to enable this functionality. The opening and closing times must be significantly less than the compressor pumping time. For the valves EX4/5/6 the average operating time is less than 1 second, with a fully open to fully closed time of 1.5 sec. With a minimum pumping time of 2 sec for the scroll this gives adequate control functionality. The EC3-Dxx is suitable for installations with two similar size compressors as well as single compressor installations. Where two compressors are operating in parallel, compressor 2 being fixed load and compressor 1 being Digital, it is necessary to have a signal to indicate that compressor 2 is running. Then the closure of the expansion valve is limited so that approximately half the capacity is maintained during its idle period.

The available EC3-DXX versions are shown in the diagram below:

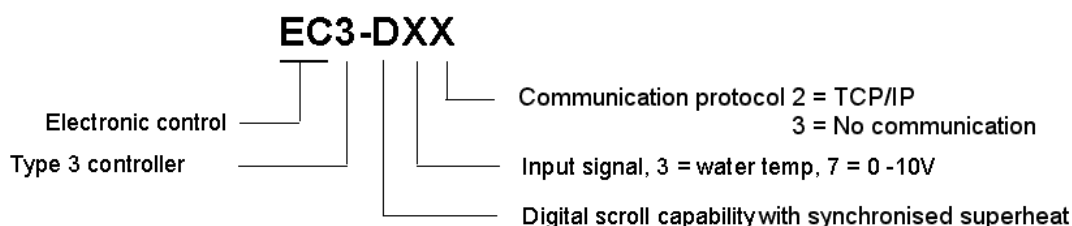

NOTE: It should be remembered the EC3-DXX is NOT a rack controller! It is designed to synchronise the digital scroll capacity valve and the superheat.

Separate detailed instructions for setting up the EC3-DX2 types are available.

4.1.3 Digital Superheat Controllers

The new EC3-D72/EC3-D73 series Digital Superheat Controllers from Emerson Climate Technologies are specifically designed for use with Copeland Scroll Digital applications. Together with the electrical control valves EX4, EX5 and EX6 they provide constant superheat control in the evaporator while synchronizing the operation of the Copeland Scroll Digital for optimum system performance.

Description of performance

EC3-D7x series controls the opening of electrical control valve according to desired superheat. As the Emerson electrical control valves (ECV) are able to provide a better positive shutoff function than conventional solenoid valves, there will be no flow through Emerson ECV when the compressor(s) are not running. In the event of a cooling demand request from a third party controller and the Copeland Digital Scroll compressor starts up, the EC3-D7x needs to be informed through a digital cooling demand input. In addition, upon receiving a capacity demand signal through the 0-10V input, the Digital Scroll will initially run at minimum capacity and will subsequently start to vary the capacity of the compressor. The EC3-D7x will start to control the refrigerant mass flow by precise positioning of the ECV under different operating conditions such as compressor start-up, start of second compressor, high head pressure, low head pressure, high load, low load and partial load operation. EC3-D7x is capable of alarm handling and diagnostics. The alarm can be received via relay output, via TCP/IP network as well as optical LED/alarm code on ECD-002.

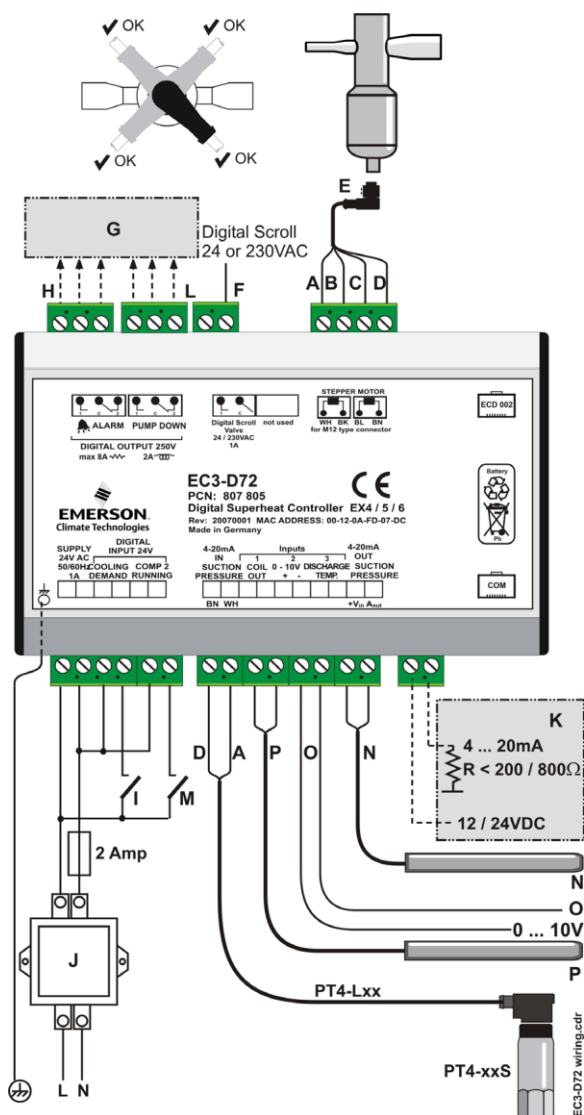

A: White wire **B:** Black wire **C:** Blue wire **D:** Brown wire
E: Plug cable assembly EX5-Nxx for connection to EX4/EX5/EX6

Figure 16: EC3-D72 / D73

4.2 Control with specific controllers

For integration with an existing control system the system controller needs to be modified to have digital control capability (hardware and software). Some controllers are already available on the market with digital control capability.

For multi compressor racks the controller requires the following:

Inputs:

- Suction pressure transducer;
- Discharge temperature - The controller needs to be able to integrate the NTC probe imbedded in Digital. As an alternative a simple discharge thermostat can be used.

Outputs:

- A 15W output to the solenoid valve to control the unloader solenoid. Either 24 V or 230 VAC depending on solenoid coil used. It must provide for high cycle relay output such as triac.

The compressor contactor is the same as for standard scroll. For discharge temperature protection, a NTC thermistor is factory delivered with the Digital compressor and the setting for the cut-out is 140°C, or a standard DTP discharge line thermostat can be used as an alternative.

Operational cycling time should be fixed at 20 seconds in the software with a minimum loaded time of not less than 2 seconds. It should include an algorithm to filter the suction pressure reading or to filter the PWM output. The interaction with the system controller is similar to inverter controlled compressors. Testing should be carried out by the OEM laboratory.

5 Quick ordering guide

Emerson Climate Technologies has compiled complete kits in order to facilitate ease of integration of Digital Scroll technology. Details of kit components are listed.

EC2-552 Kit

Copeland Kit No 8557704



Description	Type	Alco Ident	Quantity
Kit EC2-552 Digital Control		808019	
EC2-552 Controller	EC2-552	807738	1
Terminal kit	KO2-540	800070	1
Pressure transmitter, 7 bar	PT4-07M	802332	1
Pressure transmitter, 30 bar	PT4-30M	802334	1
Cable assembly 3m	PT4-M30	804804	2
Transformer 24V, 20VA, DIN rail	ECT-323	804424	1

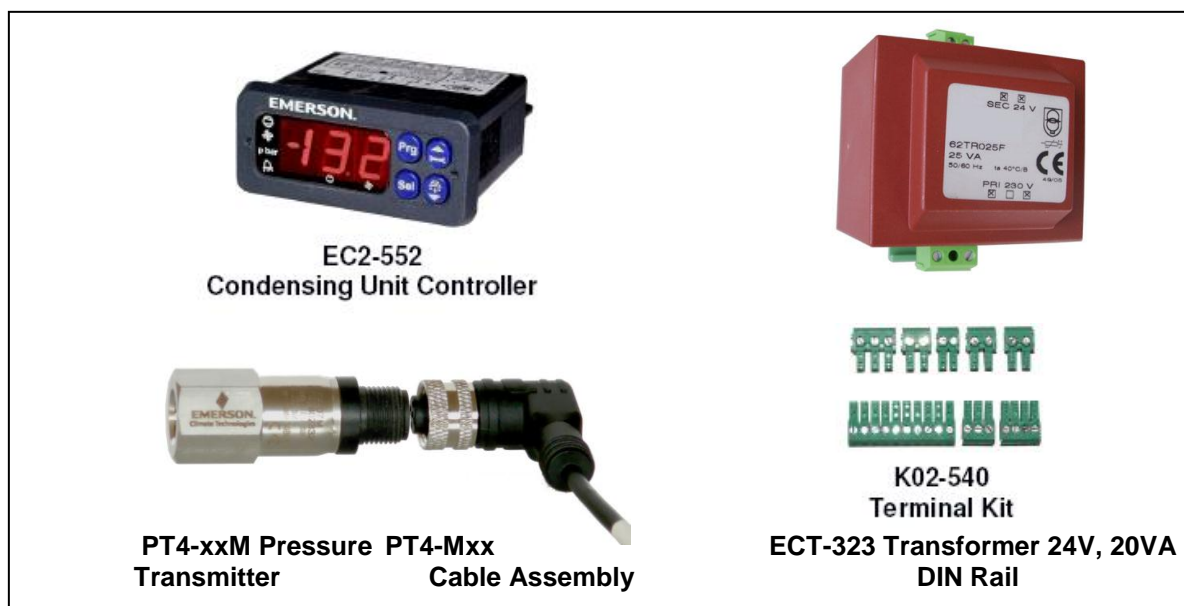

EC3-652 Kit



Description	Type	Alco Ident	Quantity
Kit EC3-652 Digital Control		808046	
EC3-652 Controller	EC3-652	807534	1
Terminal kit	KO3-110	807656	1
Pressure transmitter, 7 bar	PT4-07M	802332	1
Pressure transmitter, 30 bar	PT4-30M	802334	1
Cable assembly 6m	PT4-M60	804805	2
Transformer 24V, 60VA, DIN rail	ECT-623	804421	1
Discharge sensors	ECN-H60	804359	4

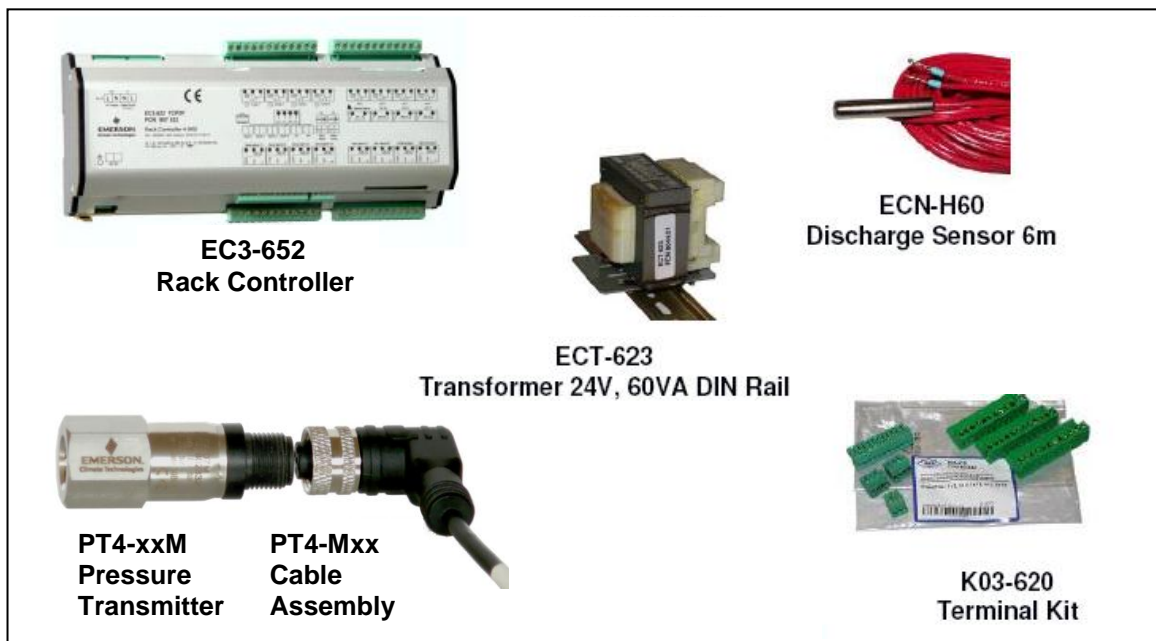

OEM's that require the display and cable can order the accessories through Emerson Climate Technologies.



Description accessories	Type	Copeland Ident	Quantity
Display	ECD-000	8557771	1
Display cable	ECC-N10	8557782	1

EC3-D72 / D73 Kits

Description	Type	Part code no
Digital Superheat Controllers with communication: Complete kit for 7 bar applications	EC3-D72	808042
Digital Superheat Controllers without communication: Complete kit for 7 bar applications	EC3-D73	808041

The kit consists of: controller, terminal kit, pressure transmitter including 6.0 m cable, 6.0 m temperature sensor, 60 VA transformer.

Description		Type	Part code no
Digital Superheat Controller EC3-D72		EC3-D72	807805
Digital Superheat Controller EC3-D73		EC3-D73	807804
Terminal kit for EC3-X32		K03-331	807648
Pressure sensors	-0.8 ... 7 bar	PT4-07M	802332
	0 ... 18 bar	PT4-18M	802333
Cable assembly for PT4	1.5 m cable length	PT4-M15	804803
	3 m cable length	PT4-M30	804804
	6 m cable length	PT4-M60	804805
NTC Temperature sensors	3 m cable length	ECN-N30	804496
	6 m cable length	ECN-N60	804497
	12 m cable length	ECN-N99	804499
Display /keypad unit (optional)		ECD-002	807657
Connection cable EC3 to ECD-002	1 m	ECC-N10	807860
	3 m	ECC-N30	807861
	5 m	ECC-N50	807862

Ordering accessories, spare parts

Transformer		Type	Part code no
230 V Input, 24 V output, DIN rail mounting			
For one set of controller and valve	25VA	ECT-323	804424
For two sets of controllers and valves	60VA	ECT-623	804421
Replacement battery kit			807790

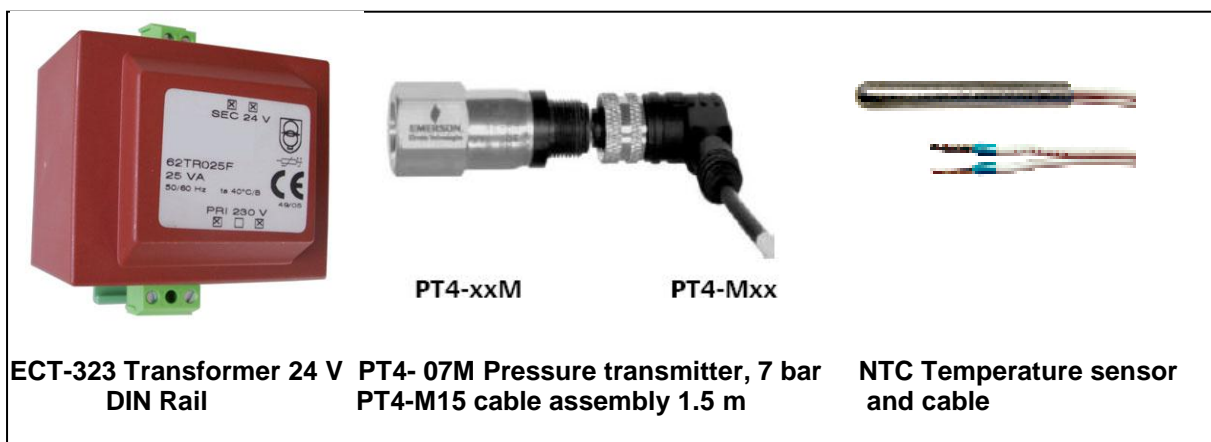

**ECT-323 Transformer 24 V
DIN Rail**

**PT4- 07M Pressure transmitter, 7 bar
PT4-M15 cable assembly 1.5 m**

**NTC Temperature sensor
and cable**